

**Slingshot  
Final Proposals  
Team F7  
Abdulla Howaishel  
Dhary Aldhefeeri  
Abdullah Alzafiri  
Fahad Alotaibi  
Mubarak Alsuabiee**

**2017-2018**

**NORTHERN  
ARIZONA  
UNIVERSITY**



*College of  
Engineering, Forestry  
& Natural Sciences*

---

**School of  
Forestry**

**Project Sponsor: The Wonder Factory**

**Faculty Advisor: Dr. Sarah Oman**

**Sponsor Mentor: Dr. Sarah Oman**

## **DISCLAIMER**

Students prepared this report as part of a university course requirement. While considerable effort has been put into the project, it is not the work of licensed engineers and has not undergone the extensive verification that is common in the profession. The information, data, conclusions, and content of this report should not be relied on or utilized without thorough, independent testing and verification. University faculty members may have been associated with this project as advisors, sponsors, or course instructors, but as such they are not responsible for the accuracy of results or conclusions.

## EXECUTIVE SUMMARY

Wonder Factory is a place in Flagstaff which has different creative games for the enjoyment of children. Different products placed in Wonder Factory are unique and creative, and used for children in their learning as well as the basis for STEM.

The purpose of this project is to come up with an idea which is useful for children and which they can play with. It must have a sort of wow factor and it must be interesting, entertaining and simple as well. With all these requirements, the team will decide to make a design project based on slingshot.

This paper discusses old and existing designs. Furthermore, engineering and client requirements have been presented along with the House of Quality matrix. Then, few designs have been generated and out of those designs one design has been selected on the basis of the Pugh Chart result. From the Pugh Chart the design which has been finalized is a customized design which has a game zone area and a targeted wall. Slingshot is used to hit the target by throwing the ball at it.

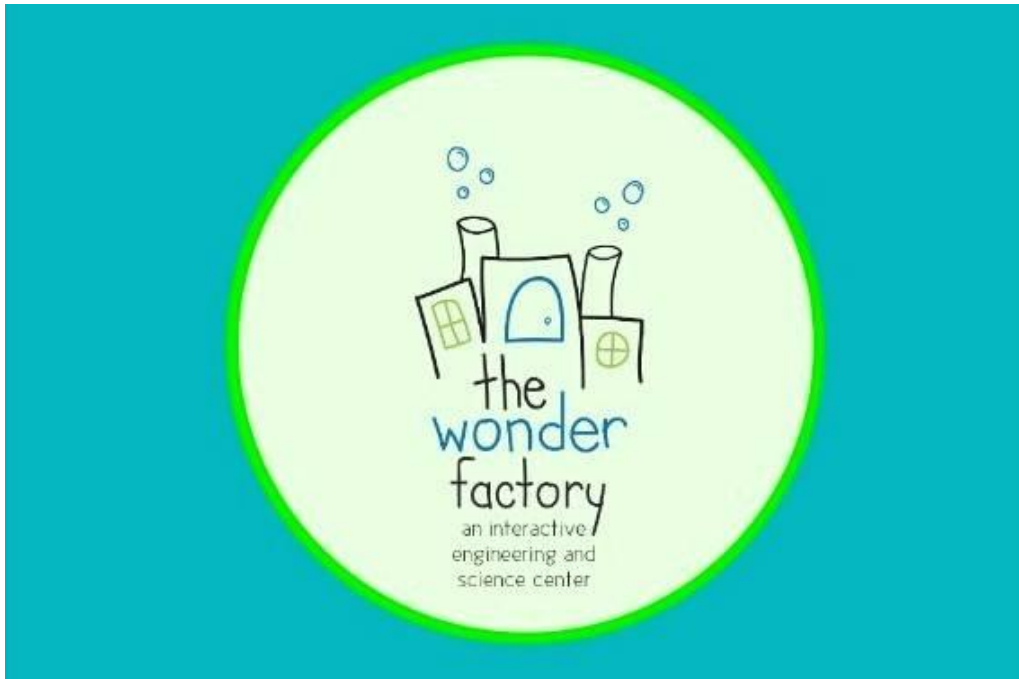

Figure 0: Wonder Factory Logo [1]

## ACKNOWLEDGEMENT

Our team would like to thank the people who have showed their positive response towards our project and helped us in all matters related to the project. First of all we would like to say thanks to our client Dr. Sarah Oman who helped us, and giving us a chance to work on such a great idea. Next we would like to thank The Wonder Factory especially Steve and Jackee without their efforts we will not been able to work on such an idea. And the last one to thank is our university Northern Arizona University, because they gave us all the knowledge that we need to break down all the difficulties that we faces in the past 4 studying years. In addition, I would thank student success center particularly Kelsey Rendon for their help editing our report for grammar and spelling mistakes.

## Table of Contents

<b>DISCLAIMER</b> .....	<b>ii</b>
<b>EXECUTIVE SUMMARY</b> .....	<b>iii</b>
<b>ACKNOWLEDGEMENT</b> .....	<b>iv</b>
<b>1 BACKGROUND</b> .....	<b>1</b>
<b>1.1 Introduction</b> .....	<b>1</b>
<b>1.2 Project description</b> .....	<b>1</b>
<b>1.3 Original system</b> .....	<b>2</b>
<b>2 REQUIREMENTS</b> .....	<b>3</b>
<b>2.1 Customer Requirements</b> .....	<b>3</b>
<b>2.2 Engineering requirements</b> .....	<b>3</b>
<b>2.3 Testing Procedures</b> .....	<b>5</b>
<b>2.4 House of Quality</b> .....	<b>6</b>
<b>3 EXISTING DESIGNS</b> .....	<b>8</b>
<b>3.1 Design Research</b> .....	<b>8</b>
<b>3.2. System Level</b> .....	<b>8</b>
3.2.1 Existing Design # 1: The Scout Slingshot .....	8
3.2.2 Existing Design # 2: Torque Slingshot .....	9
3.2.3 Existing Design # 3: Outdoor Life Stainless Hunting Slingshot.....	9
<b>3.3. Functional Decomposition</b> .....	<b>10</b>
3.3.1 Black Box Model.....	10
3.3.2 Functional Model .....	10
<b>3.4. Subsystem Level</b> .....	<b>11</b>
3.4.1 Subsystem # 1: Elastic Bands .....	11
3.4.2 Subsystem # 2: Frames .....	12
3.4.3: Subsystem # 3: Holding Pouch.....	14
<b>4 DESIGNS CONSIDERED</b> .....	<b>16</b>
<b>4.1 Design #1: Scout slingshot</b> .....	<b>16</b>
<b>4.2 Design #2: Torque slingshot</b> .....	<b>16</b>
<b>4.3 Design #3: Outdoor Life Stainless Hunting Slingshot</b> .....	<b>16</b>
<b>4.4 Design #4: Traditional Y shape</b> .....	<b>17</b>
<b>4.5 Design #5: Bow slingshot</b> .....	<b>17</b>
<b>4.6 Design #6: Mug Shaped slingshot</b> .....	<b>18</b>
<b>4.7 Design #7: Bone Collector Sport Slingshot, Laser &amp; Light</b> .....	<b>18</b>
<b>4.8 Design #8: Beeman Laserhawk slingshot</b> .....	<b>18</b>
<b>4.9 Design #9: Yusylvia slingshot</b> .....	<b>19</b>
<b>4.10 Design #10: Customized slingshot</b> .....	<b>19</b>
<b>5 DESIGN SELECTED</b> .....	<b>21</b>
<b>5.1 Rationale for design selection</b> .....	<b>21</b>
<b>5.2 Design Description</b> .....	<b>22</b>
<b>6.1 Resources</b> .....	<b>25</b>
<b>Room walls</b> .....	<b>26</b>
<b>Wood</b> .....	<b>26</b>

<b>We will be using all the materials that provided to us to create our project. We will using a lest of equipment listed in the down table:.....</b>	<b>26</b>
<b>6.2 BOM.....</b>	<b>26</b>
<b>6.3 Cost and Budget .....</b>	<b>26</b>
<b>6.4 Schedule .....</b>	<b>27</b>
<b>References .....</b>	<b>28</b>
<b>APPENDIX A: Bill of Materials.....</b>	<b>0</b>
<b>APPENDIX B: Gantt Chart .....</b>	<b>4</b>

# 1 BACKGROUND

The idea for this project is to come up with any idea that will help children with disabilities to play around and this idea will place in Wonder Factory.

Wonder Factory is a place in Flagstaff which has different creative games for the enjoyment of children. Different products placed in Wonder Factory are unique and creative, and used for children in their learning as well as the basis for STEM.

In order to make such a project which will amuse the children with disabilities we have decided to make something with slingshot. Slingshot is an old way of throwing things, this was used in old ages in wars and transfer things from one place to another place.

## 1.1 Introduction

In 2014, a total of 357 Flagstaff citizens were interviewed on the suitability of children play facilities in Flagstaff. Out of those 357, 71% of them said that what current Flagstaff attractions offered was not suitable to meet children's needs, mostly due to the lack of interactive displays [1]. Eighty-four percent of those interviewed also said if something like The Wonder Factory was available, they would visit it and 58% said they'd visit monthly [1]. Additionally, The Wonder Factory visitation can also come from the 4.7 million tourists traveling to Flagstaff each year, 23% of which bring children with them and have no children's-style attraction to visit in Northern Arizona. It is on the basis of these findings that our project was conceptualized.

This project aims at initiating a product to be used in the Wonder Factory where learning can be generated through play [1]. Wonder Factory believes that the next generation must be given opportunities for hands-on, interactive experiences to take their positions as the thinkers, the makers, and the creators of the future. Specifically, our project focuses on designing, developing and commissioning a device that can be part of the wonder factory. The device has to meet all the required specifications and requirements so as to be able to solve the solution at hand [1].

## 1.2 Project description

The purpose of this project is to make such a product which will amuse the children with disabilities so we have decided to make any product using the slingshot. Slingshot will allow the children to spend their time in fun and as slingshot is a moveable item as well so they can carry it to any place. That is why we have decided to make anything using Slingshot. The final product will select by the end of this report.

The following is the original project description provided by our client Wonder Factory:

The Wonder Factory is a science, engineering, art, and technology center in Flagstaff, AZ providing hands-on, interactive experiences for the young and young at heart. It was founded by Jackee and Steve Alston as a movement of concerned citizens working towards getting a STEM/STEAM-based play center in Flagstaff. The Wonder Factory's goal is to lead the next generation of young minds into their place as the thinkers, the makers, and the creators of the future through hands-on interactions with science, technology, engineering, art, and mathematics. Your task is to generate lots of interactive display ideas and to ultimately design, build and test one final display ready for public consumption. Your final design must:

- Must be safe to all users per applicable safety standards. Safety is your first priority!!
- Must be ready upon completion of this capstone sequence
- Should generate up to 100 ideas – including existing, new, wacky, and off the wall concepts
- Must select, design, build, and test one final unique idea

- Should test the interactive display in a similar setting to expected everyday use
- Must raise some of the funds required to finish the project
- Must raise some of the funds required to finish the project

### **1.3 Original system**

This project involved the design of a completely new slingshot system. There was no original system when this project began.



## 2 REQUIREMENTS

In order for our project to be useful and solve an existing problem, it was important to consult with other relevant stakeholders that were affected in one way or another by this project. The stakeholders were the key and the Wonder Factory was our client. The team is designing a product that is going to be used by kids and as such, certain requirements have to be met so as to make sure the interests of the user, the kids in this case, were well incorporated in the project. Additionally, we had to meet the needs of our client while at the same time achieving other goals such as compatibility with any existing regulations, minimal budget and high efficiency. It is for this reason that we came up with the engineering requirements that would ensure that our project was acceptable even by local and international standards.

### 2.1 Customer Requirements

According to our client, the basic requirement for the device was that it must have a “wow factor”. Aside from the kids coming to play with the device without any assistance, the device should be able to trigger the kid’s mind and make them fascinated by the simplicity yet the effectiveness of the device. Additionally, since the device had to be operated by kids without any assistance, that meant that it had to be simple. Other customer requirements were as summarized in the table below.

Table 1.1: Customer needs summary

Customer Requirements	Description of customer requirement
Safety	Every exhibit should be <b>safe to operate</b> .
Wow factor	Every exhibit is a celebration of <b>child-like wonder</b> , (i.e. have a wow factor)
Simplicity	Exhibits should be as <b>simple to operate</b> as possible.
Reality	Exhibits should be places where a visitor can <b>project themselves into the role</b> of that reality as much as possible. (i.e. They should see themselves as an engineer, a scientist, a storyteller, a medical professional, naturalist, or an artist.)
Empowerment	Exhibits should empower visitors to " <b>feel</b> " <b>smart</b> so they will excel in perpetuity
Entertaining	Exhibits should be able to entertain <b>multiple visitors</b>
Easy to Move	Portability factor to move the product easily anywhere

### 2.2 Engineering requirements

The engineering requirements came both from our team and also as guided by the customer requirements. Key to this was safety. All materials used in the design had to embrace safety of the user and also of the team building the design. Other engineering requirements included; weight that should be met and strength of device. The engineering requirements are summarized in the table below.

Table 1.2: Engineering Requirements

<b>Engineering requirements</b>	<b>Targeted Values</b>	<b>Accuracy</b>
Range of Ball	4 Meters	$\pm 1$ Meters
Height of Ball	3 Meters	$\pm 1$ Meters
Angle of Projectile	45°	$\pm 3^\circ$
Weight of Ball	0.5 Kg	$\pm 0.2$ Kg
Elasticity in Rubber Band	300mm elastic Length	$\pm 150$ mm
Energy Transmit	1 kJ	$\pm 200$ J
Weight of Product	30 Kg	$\pm 5$ Kg
Edge Break Radius	1 cm	$\pm 0.5$ cm
Weight of Target	10 Kg	$\pm 3$ Kg
Number of Targets	3	$\pm 1$
Distance between target and slingshot	4 meters	$\pm 1$ Meters
Diameter of Ball	0.1524 meter	$\pm 0.02$ Meters
Size of Target	0.381 meter	$\pm 0.0762$ Meters
Length of Rubber band	0.3048 meter	$\pm 0.0508$ Meters
Front Wall	3x3 meter	$\pm 1$ Meters

### **Range of Ball**

The maximum limit the ball can go towards the target is the range of ball. Range for any projectile motion is the maximum distance covered in horizontal direction so the distance from the slingshot towards the ball will be the range covered by the ball.

### **Height of Ball**

The maximum height achieved by the ball at a specific angle. This is the height achieved by the ball during the projectile, and this height will be calculated from the horizontal axis and the horizontal axis will equal to the point from where the ball has been thrown. During that projectile the ball will reach a specific height, which is usually the center point of projectile motion. Distance from the slingshot to the maximum height will be the height of ball.

### **Angle of Projectile**

The angle of projectile would be the angle at which the ball will be thrown through. The angle that the projectile will make with its horizontal axis is the angle of throw. This angle is important because the ball will reach the target if the throw was at the correct angle. Slingshot takes the target by making some angle and that angle calculates by the horizontal surface so when the ball will throw it will throw at some angle.

### **Weight of ball**

The ball's weight a slingshot can maximum send. As a ball with heavy weight needs more elastic force to reach the target and the ball, which is lighter, will need less elastic force to hit the target. That's why the weight of ball is important for projectile motion.

### **Elasticity in Rubber Band**

The maximum expansion that the rubber band can give is the elasticity and that elasticity will store the energy and when the energy will store and rubber band will release it will throw the ball.

### **Energy Transmit**

As the elastic energy will throw the ball so the elastic energy will convert into kinetic energy and then the ball will be thrown towards the target with that energy, so energy will determine it. When the rubber band will stretch, it will save the energy and that energy will hit the ball towards the target.

### **Sharp Edge**

Any sharp edge can harm the children so the product must not have sharp edges. Like every wall must have round edges.

### **Weight of Target**

As the target will hang on the wall so the weight of that target is basically weight of target.

### **Number of Targets**

As there must be some defined number of targets so total number of targets will be three.

### **Distance between target and slingshot**

The distance between the target and the slingshot is the maximum distance which is 4 meters.

### **Size of Ball**

Ball that will throw towards the target has some size so it defines that radius of that ball will be 6 inch maximum.

### **Size of Target**

Each target will have the same size and size of target is 15 inch.

### **Length of Rubber Band**

As the rubber band will stretch so the maximum length of rubber band will be 12 inch.

### **Front Wall Size**

Size of front wall will be around 3 x 3 meters.

## **2.3 Testing Procedures**

In order to test the engineering requirements the following tools and machines must be used. The testing procedures are used to verify that engineering requirements meet the targeted values stated in the ER section.

### **Range of Ball**

The range of ball can be measured with a metric units tape measure. The ball will be launched and the distance measured to the nearest millimeters. A tape measure of at least five meters in length will be needed, with a resolution of 4-5 metres.

### **Height of Ball**

The ball height can be measured through a scale. A simple scale available in the market can do this, by just throwing the ball towards the target and measure the distance in the sky. We can detect the most accurate distance by recording it by the high-speed video cameras.

### **Angle of Projectile**

The projectile angle can be determined through the Semi-Circle scale by placing it on the horizontal axis. This can easily measure through the scale available in the market.

### **Energy Transmit**

It can calculate through the elastic force apply by the rubber band or can determine by finding the velocity of ball. We can detect the most accurate velocity of the ball by recording it by the high-speed video cameras. After that we will measure the kenotic energy.

### **Sharp Edge**

Any sharp edge can harm the children so the product must not have sharp edges. Like every wall must have round edges. Edges can calculated through the scale which is available easily in the market.

### **Weight of Target**

As the target will hang on the wall so the weight of that target is basically weight of target. Weight can measure through the scale easily available in the market.

### **Number of Targets**

Count the number of targets.

### **Distance between target and slingshot**

Distance will measure through the measuring tape which available in the market.

### **Size of Ball**

Size of ball can calculate easily by the scale. It can be measure by the circumference of ball and through the formula to calculate the radius of the ball.

### **Size of Target**

Target size will also measure in the same way as the ball.

### **Length of Rubber Band**

Rubber band length will also measure through the scale easily.

### **Front Wall Size**

Size of wall can calculate through the measuring tape, simply measure the length and width.

## **2.4 House of Quality**

The customer needs and the engineering requirements comprise the two main parameters for our design. The two result to dissimilar effects and impacts on the design. The HOQ will be useful in the planning process for our design, which will start with the voice of the customer. It will enable us to think together.

These parameters possess different weights that they enforce on the exhibit when they are re-weighed relative to each other. HOQ is useful when weighing the parameters that are in the HOQ relative to one other. From this evaluation it can concluded that the parameters are most significant to contemplate in the design process.

Table 1.3: HOQ model

House of Quality (HoQ)																
Customer Requirement	Weight	Range of ball	Height of Ball	Angle of Projectile	Weight of Ball	Elasticity in Rubber Band	Energy Transmit	Weight of Product	Sharp Edge	Weight of Target	Number of Targets	Distance between target and slingshot	Size of ball	Size of Target	Length of Rubber Band	Front Wall Size
Safety	9	3	3	9	1	1	3	9	9	1	9	3	1	3	3	3
Wow Factor	3	3	3	3	9	3	9	3	3	9	3	3	9	9	3	
Simplicity	3	1	1		3	9	1	1		3	3	1	3	1	1	3
Reality	9	9	1	3			1		3		3	9		1	1	
Empowerment	3	1	1	1	1	1	3	3	1	1	1	1	1	3	1	3
Entertaining	3	3	1	3	3	9	1	1	3	3	1	3	3	1	1	1
Easy to Move	1	1	1	1	1	1		1	1	1	1	1	1		1	
<b>Absolute Technical Importance (ATI)</b>		133	55	130	58	76	78	106	130	58	133	133	58	78	55	48
<b>Relative Technical Importance (RTI)</b>		10%	4%	10%	4%	6%	6%	8%	10%	4%	10%	10%	4%	6%	4%	4%
<b>Target ER values</b>		4	3	45	0.5	300	1000	30	-	10	3	4	6	15	12	9
<b>Tolerances of Ers</b>	%	1	1	3	0.2	50	2	5	-	3	0	1	2	3	2	2
<b>Testing Procedure (TP#)</b>		m	m	deg	kg	mm	J	kg	-	kg	-	m	in	in	in	m

The HOQ shows the relation between engineering requirements and client requirements. From the relation it has clear that the top engineering requirements according to the customer requirements are range of ball, angle of projectile, sharp edge must not be there, distance between the slingshot and target. As these requirements are the major design requirements that's why they got the priority.

### **3 EXISTING DESIGNS**

For a long time, kids have taken Y-shaped branches, overextended some surgical tubing or a heavy rubber band over it, and shot at tin cans, birds, and windows on abandoned buildings. Slingshots have existed before. However, our design has been customized to have additional features that did not exist in previous designs. Common to all existing designs is that they focused on the materials. They needed to be light but not too light. They need to be strong and not brittle, and they need to be able to be formed into somewhat complex shapes. Lastly, the materials need to have an attractive finished look.

#### **3.1 Design Research**

Design research is fundamental to making services, products, and systems that answer to human requirements. In the international and public development sectors, comprehending and meeting human requirements is important for better livelihoods and improved governance [1]. In our case, design research will provide engineering insights that focus on design analyses of previous models and existing designs. We conducted primary research fundamentally so as to generate new data to comprehend our client as well as helping users concerning their needs and what we would possibly plan on designing. It enabled us to validate our thoughts with our users and design a further eloquent solution for them. We collected this data via surveys, interviews with individuals, and questionnaires. Our main interview was done with our client so as to understand their basic requirements for their dream exhibit. It is upon these interviews that we obtained a set of customer needs as listed in Table 1. Surveys were done of several children's playgrounds in order to see what kind of play facilities were available for children to play. However, we were not successful in finding any slingshot play devices on any of the playgrounds. Nevertheless, typical Y shaped slingshots were found with some boys and they could use them for shooting at birds for fun. We additionally conducted a secondary research utilizing prevailing data including the Internet, articles, and books to back up our design choice and the perspective behind our design. Secondary research is also used as an approach to further authenticate user comprehensions from the primary research and generate a stronger case for the whole design [2]. This research helped us to identify and analyze several designs as will describe in detail the system level below.

#### **3.2. System Level**

System-level design is a procedure where the engineer takes accountability for all the constituents of a system when scheming the solution [3]. For the slingshot, for example, the system designer considers the functionality of the device, the different parts that make up the slingshot, and the materials used to make the different parts.

##### **3.2.1 Existing Design # 1: The Scout Slingshot**

This Slingshot is a 100% American finished, high-quality hunting slingshot. It's made ultra-tough from a contemporary polycarbonate material that is utilized in the firearms industry. The Scout comprises the best performers among hunting slingshots, offering sufficient power, precision, and robustness to fulfill anyone requirements. It obtains its power for shooting from heavy-duty flat bands. Its glass filled nylon frame renders it lightweight, yet robust to the roughest usage. One feature that stands out about this slingshot is its simplicity. Nearly nothing can go wrong with it considering its simple, yet functional build.



Figure 1: Scout slingshot [3]

### 3.2.2 Existing Design # 2: Torque Slingshot

This is a solid choice from Simple Shot, and it is made from ultra-strong glass packed nylon. This kind is nearly unbreakable. Indeed, it's manufactured to the utmost standards of quality in the USA. It is one of the smallest hunting slingshot choices in the market and its compact size and lightweight makes it perfect for carrying in the pocket as well as putting it in a bug out bag. Its simple design tells volumes as far as design goes. This model was conceived by Simple shot with the assistance of Mark Seljan, an industrial designer. It's modest, sturdy, and functional. The Slingshot comes equipped to shoot with 2040 twisted tubes, but it can as well handle powerful flat bands. This can simply be changed out through its fork slots.



Figure 2: Torque Slingshot [4]

### 3.2.3 Existing Design # 3: Outdoor Life Stainless Hunting Slingshot

This is a flexible design that can be adjusted and offers a completely adjustable solid steel frame. It is heavier than other designs, but it's however super strong and gives a bit of customization with the position of the fork. It is assembled with a solid steel frame, which enables fork position tunings to deliver the best shooting position. Additionally, it can be adjusted on the fly quite easily with a single big steel screw. This as well makes it more adaptable if it is necessary to add longer or shorter bands. The ergonomic precast handle is non-slip and provides the grip required in whichever conditions. One thing to note is that it weighs more than other models as a result of its steel frame and bigger molded handle.



Figure 3: Outdoor Life Stainless Hunting Slingshot [4]

### 3.3. Functional Decomposition

The functional decomposition describes a set of steps in which the overall function of a device, system, or process is broken down into its smaller parts. This is usually accomplished through thoughtful analysis and team discussions of project information and the result is a chart that describes the problem and or solutions in increasing detail. Following is the black box model for the current system.

#### 3.3.1 Black Box Model

Here is the black box model of game

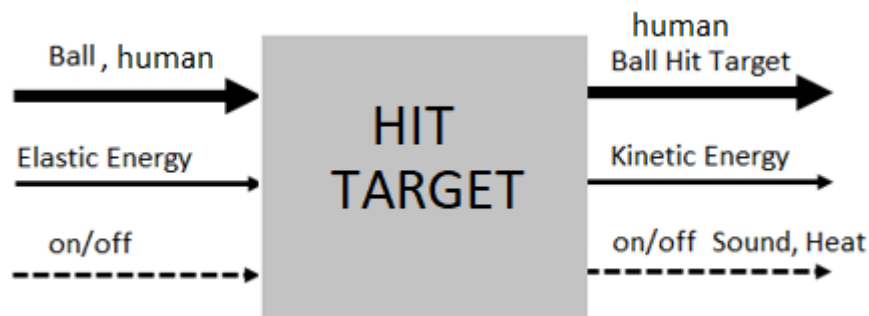

Figure 4: Black Box Model

This model is useful for understanding the inputs and outputs of the system. As the system has three inputs which are the ball, elastic energy and a signal of the on and off the system. The three outputs are hitting the target through the ball, kinetic energy obtained by the ball to hit the target and the on and off signal. Sound and heat will also release when the ball hits the target. The black box model for any system identifies the inputs and outputs without knowing the workings of the system inside the product. To view the workings inside the system, we need the functional model.

#### 3.3.2 Functional Model

Following is the functional model for the slingshot design project:



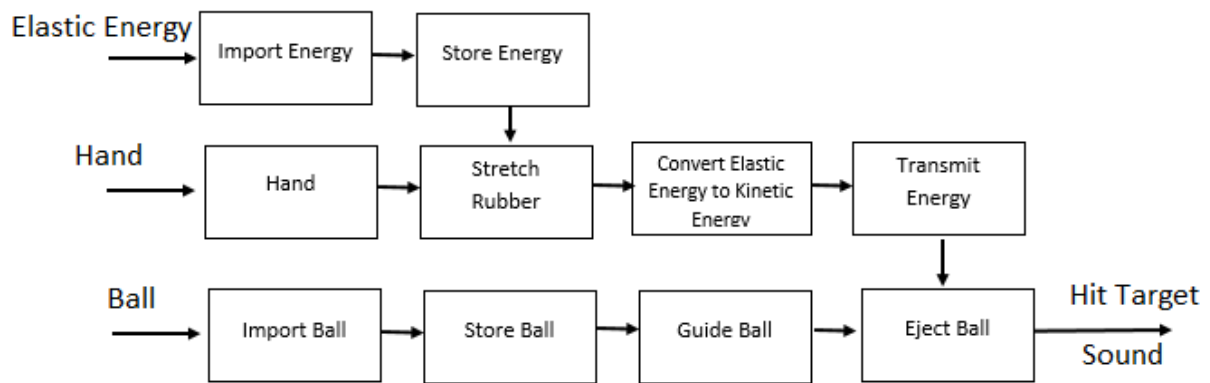

Figure 5: Functional Model

The sole aim of the device is to enable kids to play with minimal supervision while efficiency is achieved. For this to happen, our device will be able to employ two functionalities at ease. These will be the throwing and striking functions. Mechanical energy will be employed via the human hand to stretch the slingshot, which is holding the ball. This will build up potential energy that will see the ball move towards the target when released. The dangling boxing balls possess potential energy, which will be used to hit the approaching ball, building up pressure, which will direct the balls to the pulley system.

Before the drawing of our functional decomposition chart, the problems, processes, and overall projects seemed intricate. However, this complexity vanished as soon as we took a closer look and broke them down into meeker portions. Comprehending the precise functions and sub-functions that made up the system made it easier for more effective organization and enhanced planning. Additionally, each function could be viewed as an independent unit, making it conceivable to restrict problems at the lowest level.

### 3.4. Subsystem Level

The subsystem level comprises the smaller mechanisms of the design that have a critical role in the successful performance of the considered systems. Several sub-systems were considered in this design as discussed below.

#### 3.4.1 Subsystem # 1: Elastic Bands

The elastic band is one of the major components for this project, as the slingshot has two portions: one is the elastic band and the second is the frame. The elastic band is quite important for our project because a good band with good elasticity will be able to throw the ball correctly all of the time at some distance. There are multiple elastic bands already available so in this section will consider existing designs for elastic bands.

##### 3.4.1.1 Existing Design # 1: Rubber bands

The rubber bands can be regarded as the slingshot's soul. They stock and release the energy that is utilized in propelling the ammunition. Bands can be replaced, and numerous features of the slingshot change along with them. They can come in diverse forms, dependent on design and material. For instance, a band that is made of a superior quality rubber guarantees the best user experience. This elastic is available in a 6-yard length that enables consumers the suppleness to make custom slingshot band shapes and sizes. Wizard bands are intended for high speed and reliably, and deliver distance and velocity. In our project, the durability of the bands will be an important aspect to consider. It must be high quality and efficient while also having a reasonable cost.



Figure 6: Rubber Bands [2]

#### ***3.4.1.2 Existing Design # 2: Plastic Bands***

There is another type of band available on the market that is made of plastic material, but the elastic limit of such a material is not equal to the rubber band. That band is also useful for this project if it gives enough elasticity as is required by the project.



Figure 7: Plastic Bands [1]

#### ***3.4.1.3 Existing Design # 3: Plastic Tubes***

Another option is the use of plastic tubes that are already available on the market, like the tube used for the inflation of tires and the tubes used for swimming in the water.



Figure 8: Plastic Tubes [3]

### **3.4.2 Subsystem # 2: Frames**

The frame is the part that is held by the shooter, and keeps the rubber bands in place. It is not as important as it seems, but it plays its part in keeping the shooting process comfortable and

obtaining a good sight picture. Safety considerations are important when constructing the frame, as failure of this part can lead to severe injuries.

#### **3.4.2.1 Existing Design # 1: Wooden Frame**

A frame made up of wood is a good choice for this project because it is already available on the market. Wood is strong and has a good hold as well which is why it is a good option. Another thing is that wood has the least elasticity, so when making the V shaped hands, wood is strong enough to bear a lot of force exerted by the rubber band when it stretches by any human hand.



Figure 8: Wooden Frame [4]

#### **3.4.2.2 Existing Design # 2: Plastic Frame**

A frame made up of plastic is also an existing design but the problem is that plastic has higher elasticity and it is not strong enough to bear the force applied by any human hand. But, as the project is for children, the plastic frame can also be used for this purpose.



Figure 9: Plastic Frame [3]

#### **3.4.2.3 Existing Design # 3: Steel Frame**

A steel design is also a good option to use for this purpose because it is strong and can bear a force applied by any human body.



Figure 10: Steel Frame [4]

### 3.4.3: Subsystem # 3: Holding Pouch

A pouch is required to grip the projectile in place prior to and during the shot. Having it at the right weight and size is important to get a virtuous performance. Only scarce materials can endure the stress that the pouch undergoes during the shot, and as such leather is both cheap and affective for this task. It needs to be soft and supple, frivolous and robust. A typical choice is fragmented leather from cow or pig, with a thickness of 1-3mm for standard draw bulks. The best material however is kangaroo leather. It endures a lot of pressure and strain whereas being soft, supple and lightweight.

#### 3.4.3.1 Existing Design # 1: Leather pouch

A pouch of leather is good to use because the leather is rough and has high friction that's why it becomes easy to hold the ball for throwing it. As more force will apply to stretch the rubber band, at the same time it will become important to hold the ball tight.



Figure 11: Leather Pouch [1]

#### 3.4.3.2 Existing Design # 2: Rubber Pouch

Mixed rubber is also an available design for holding the ball and make the pouch for slingshot. This is also useful option for this project.



Figure 12: Rubber Pouch [1]

#### 3.4.3.3 Existing Design # 3: Rexene Pouch

This is a replacement of leather and is used intensively for such pouches. It is also useful for this project because it has a good hold.



Figure 13: Rexene Pouch [4]

#### 4 DESIGNS CONSIDERED

There are a few designs, which were created for this project, and these design are shown below along with their description.

##### 4.1 Design #1: Scout slingshot

This design is made ultra-tough from a contemporary polycarbonate material that is utilized in the firearms industry. This one comprises the best performers among hunting slingshots, offering sufficient power, precision, and robustness to fulfill anyone requirements. A stand will be made using plywood, which will form a bouncing wall to act as the ball target.

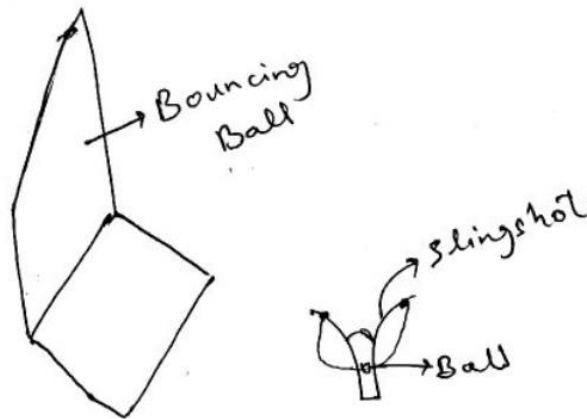

Figure 14: Scout slingshot

##### 4.2 Design #2: Torque slingshot

This one is made from ultra-strong glass packed nylon. This kind is nearly unbreakable. It is one of the tiniest hunting slingshot choices in the market and its compact size and light weight makes it perfect for carrying in the pocket as well as putting it in a bug out bag. A customized pole with a ring at the top comes with it and the aim of the game will be to place the ball inside the ring using the slingshot.

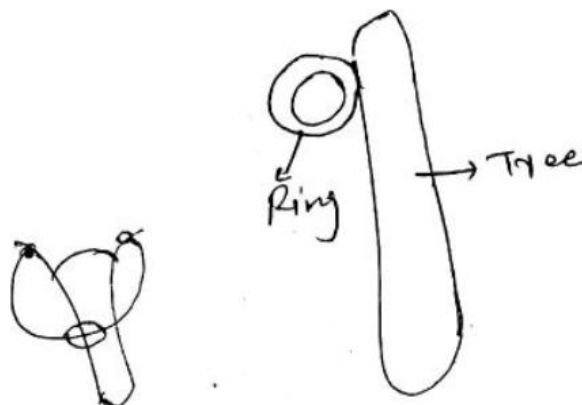

Figure 15: Torque slingshot

##### 4.3 Design #3: Outdoor Life Stainless Hunting Slingshot

This is a flexible design that can be adjusted and offers a completely adjustable solid steel frame. It is heavier than other designs, but it's super strong and gives a bit of customization with the position of the fork. A wooden block comes with it acting as the target for the ball.

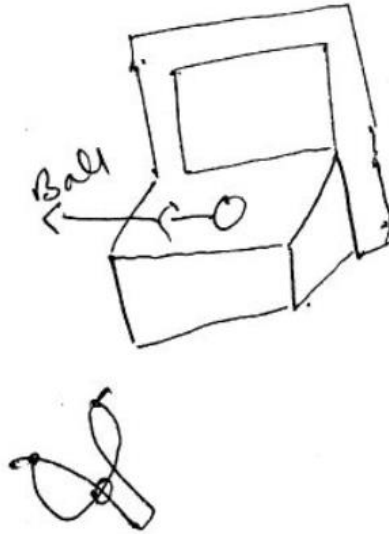

Figure 16: Outdoor Life Stainless Hunting Slingshot

#### 4.4 Design #4: Traditional Y shape

This incorporates the concept of the traditional Y shaped frame with rubber strips attached to the forks. Balls are then hanged on a post to appear like dangling fruits which children can hit.

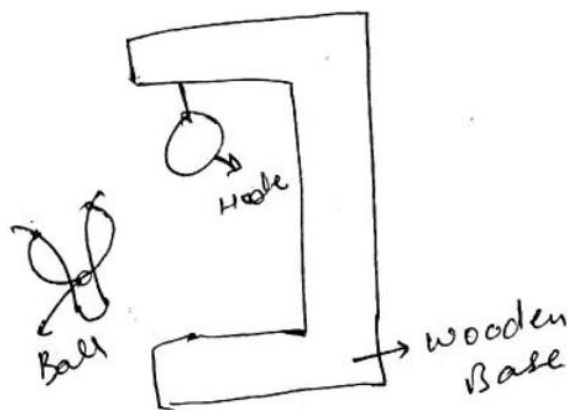

Figure 17: Traditional Y shape

#### 4.5 Design #5: Bow slingshot

This design is designed to shoot arrows. The main dissimilarity with the others is that they have an arrow rest and arrow nock. Arrow rests, like the whisker arrow rest, grip the arrow in place and enable the user to shoot with a high mark of accuracy. A dart like board hangs on a wall acting like the target.

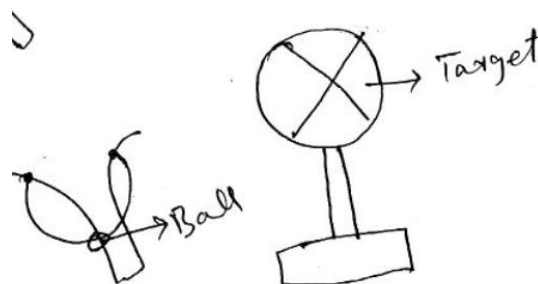

Figure 18: Bow slingshot

#### 4.6 Design #6: Mug Shaped slingshot

This one is capable of being shot with or in absence of a wrist brace, as it provides the user with the chance to have one unit to support many shooting disciplines.

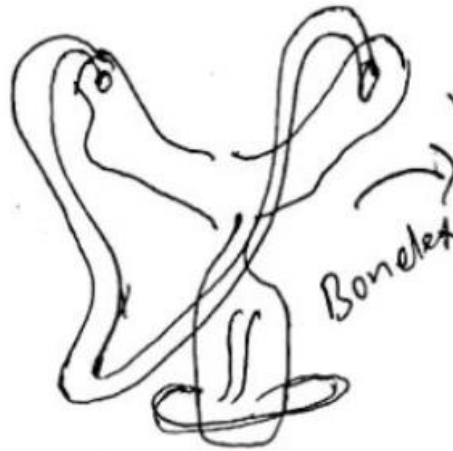

Figure 19: Mug Shaped slingshot

#### 4.7 Design #7: Bone Collector Sport Slingshot, Laser & Light

This one is designed to hold a Mini Maglite 2AA flashlight and is known to shoot day or night with bulls-eye precision and accuracy. At night the light can be switched on providing clear visibility for the target. Indeed, it possesses optic sensors that capture light rays that make the red and green sights glow for better accuracy for shooting.

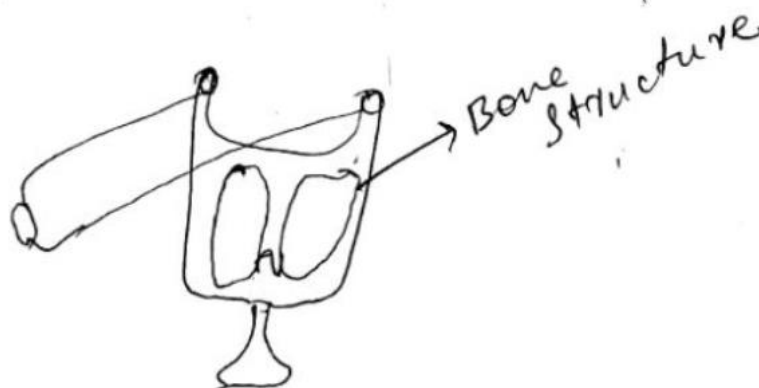

Figure 20: Bone Collector Sport Slingshot, Laser & Light

#### 4.8 Design #8: Beeman Laserhawk slingshot

This design is designed for easy keeping and fetching and has a hinged arm support that folds for appropriate storage. It also comes with a molded finger pleated grip for extra comfort, hardened steel yoke as well as an arm support, and utmost quality hollow thrust bands that shoot 1/4" and 3/8" steel shot.



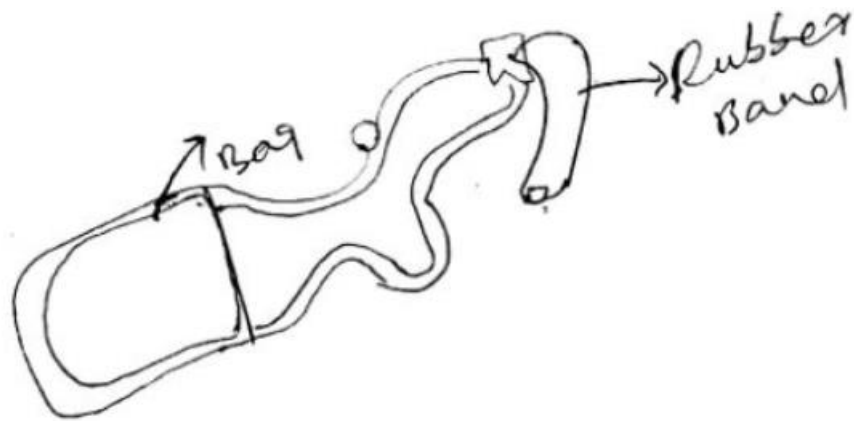

Figure 21: Beeman Laserhawk slingshot

#### 4.9 Design #9: Yusylvia slingshot

This comes with an adjustable wrist brace including a golden proportions making precision excellent in hunting. This slingshot is particularly good for a beginner. Its high speed, precision, and powerful magnetic leather renders it possible to reload bullets fast.

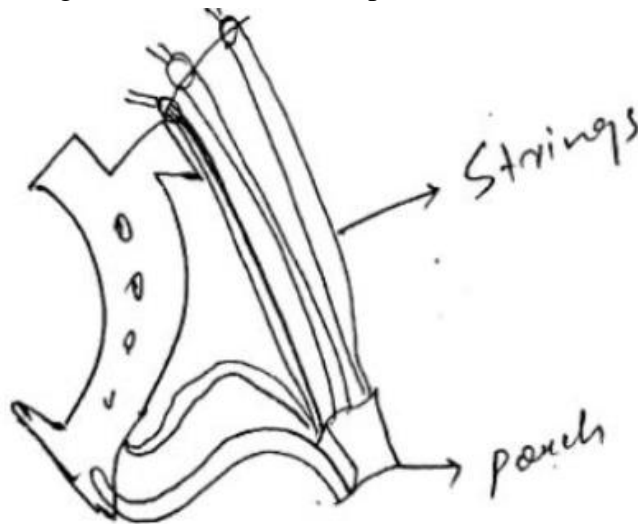

Figure 22: Yusylvia slingshot

#### 4.10 Design #10: Customized slingshot

This one is able to shoot a ball into a target which is a ring that is held on a wooden pole. Once the ball was shot into the target, a pulley is used to drag the ball back to the slingshot for it to be thrown again instead of someone going there to pick the ball.

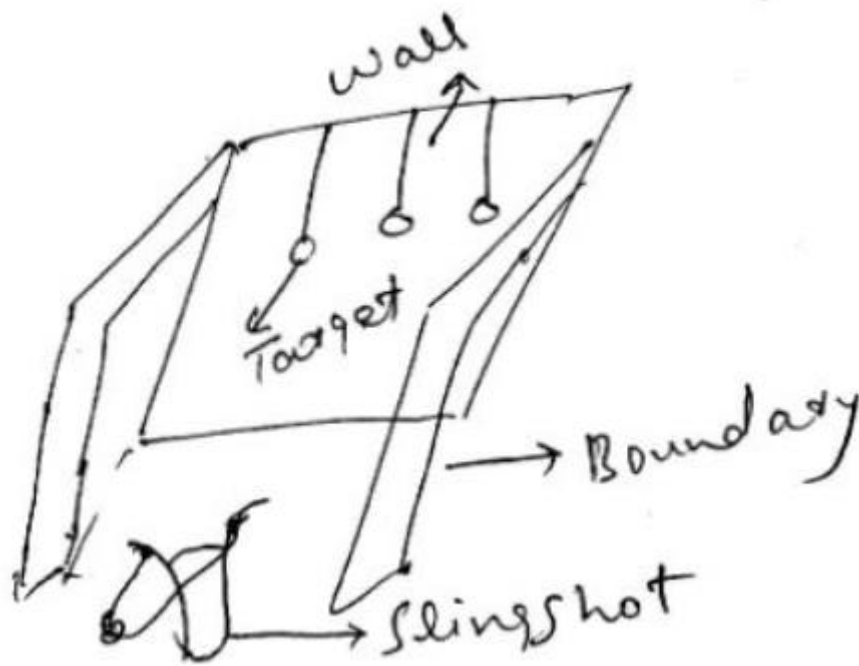

Figure 23: Customized slingshot

## 5 DESIGN SELECTED

Selection of the final design relied upon a thorough analysis of all considered designs while assessing them against the HOQ. This gave the criterion that was utilized in the design selection. The identified criteria were utilized in the decision matrix to determine the best model amongst the designs considered. After a thorough analysis and evaluation of all the designs, we selected the tenth design since it had the most desired qualities.

### 5.1 Rationale for design selection

All the customer and engineering requirements discussed in Chapter 2 were assessed critically against the ten considered designs. Scores were assigned for each design as to the degree in which it satisfied each of the requirements. In order to select the design, we have used the Pugh Chart.

Table 1.4: Pugh Chart

10 Designs for SLINGSHOT	Weight	Scout Slingshot	Torque Slingshot	Outdoor Life	Traditional Y shape	Bow Slingshot	Mug Shaped Slingshot	Bone Collector	Beeman Laserhawk	Yusylvia Slingshot	Customized Slingshot
Range of Ball	8	+	+	+	+	D	-	-	+	+	+
Height of Ball	7	S	S	+	-	A	S	+	+	+	+
Weight of Ball	6	-	+	+	+	T	-	S	+	-	+
Angle	5	+	+	+	+	U	S	-	-	-	+
Elasticity	4	+	S	+	S	M	+	-	-	S	+
Safety	3	+	+	-	-		-	S	S	-	+
Wow Factor	2	-	+	+	+		-	-	S	S	+
Simplicity	1	-	+	-	-		-	+	-	-	+
Pluses		4	6	6	4		1	2	3	2	8
Minus		3	0	2	3		5	4	3	4	0
Total		1	6	4	1		-4	-2	0	2	8

From the Pugh chart we narrowed it down to the top three designs, which then were analyzed with a decision matrix to finalize the design. Three designs were selected because they got the maximum numbers. These three designs fulfilled all the requirements for this project. In order to narrow down the final result, we will move towards the decision matrix, which will finalize it.

Table 1.5: Decision Matrix

	Range of Ball	Height of Ball	Weight of Ball	Angle	Elasticity	Safety	Wow Factor	Simplicity	Total
Weight	8	7	6	5	4	3	2	1	
Customized Slingshot	5x8=40	6x7=42	2x6=12	7x5=35	7x4=28	5x3=15	5x2=10	1x1=1	183
Scout Slingshot	4x8=32	5x7=35	1x6=6	5x5=25	6x4=24	4x3=12	4x2=8	1x1=1	143
Outdoor life	4x8=32	5x7=35	3x6=18	1x5=5	2x4=8	4x3=12	2x2=4	2x1=2	87

The decision matrix has three projects, so comparing these three projects according to the requirements and their weight as defined by the HOQ. Each project is assigned a specific number, which it possesses for the corresponding requirement, then summing up all those numbers to form the total. The highest number in total is the final result from the decision matrix.

## 5.2 Design Description

The Figure.26 below shows the chosen model through the decision-making criteria. Our choice was a customized slingshot that would be able to throw a ball into a target, which is a ring that is held on a wooden pole and an auto set target. Once the ball was thrown into the target, a pulley made out of steel would be used to drag the ball back to the slingshot for it to be thrown again instead of someone going there to pick the ball. A cubic wooden booth with dimensions of 3x3 meters will be built and in the middle of the booth will be the the dangling targets. On the opposite side, a slingshot made of steel capable of rotating up to 45 degrees will be built and the pulley will be connected to a tube on the left side of the slingshot. The shooting ball will be covered in netting made of polyethylene twine, which will be connected to a rope. The first end of it will connect to the net and the other end will connect to the pulley to drag the ball down again to the slingshot. Finally, a plastic fence with blunt edges will be built in front of the slingshot so as to contain the ball and prevent it from getting lost.

The design won due to its additional customized features that made it fit for the task intended. Additionally, the materials used in this design were durable and of high quality yet cost effective and easily available in the market. Most of all, the design brought out the “wonder factor” in an outstanding way since it had customized features that were not available in any of the other designs. This would results in the kids yearning to play with the device while learning about projectile motion at the same time. The Final CAD design is shown below from Figure 24-26

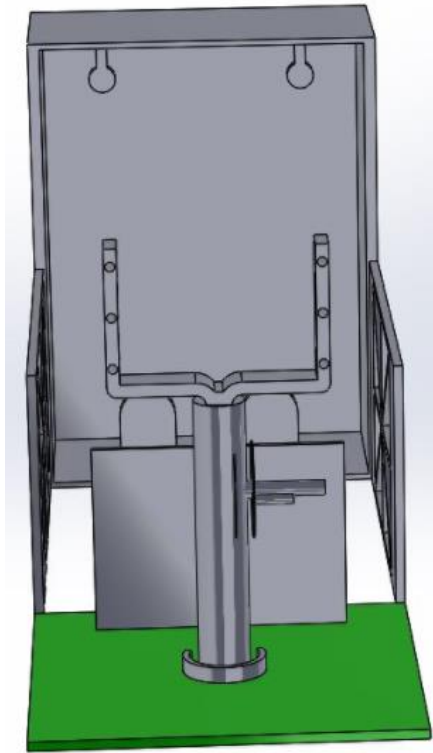

Figure 24: Front View CAD MODEL

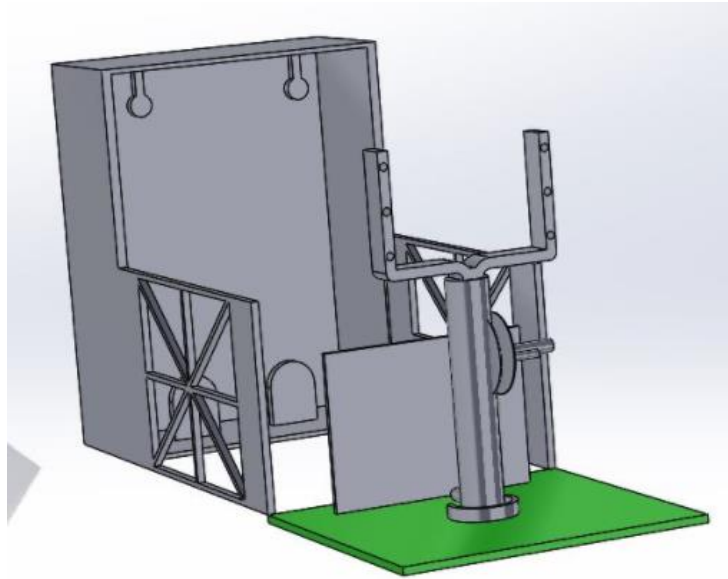

Figure 25: ISO View

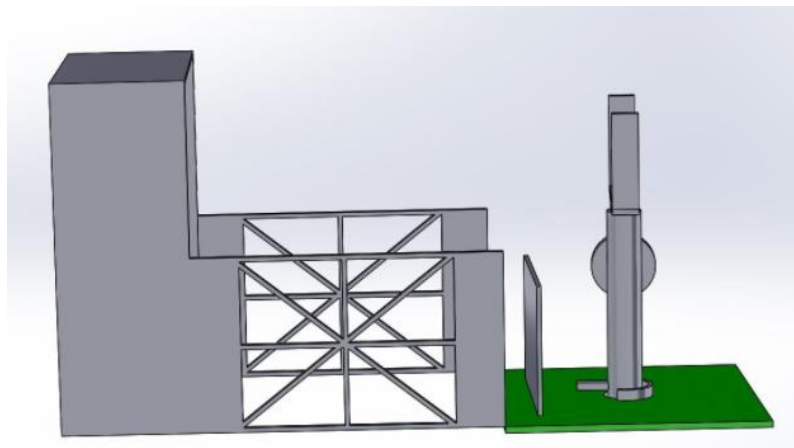

Figure 26: Side View

## 6 PROPOSED DESIGN

The design below includes a wall fence all around three sides to cover the area because the ball will go out of range while throwing it towards the target, which is why it is necessary to put the walls all around it. There is a slingshot placed in front of the area to hit the target and 2-target boxing balls will be dangling from middle of the booth and the other 2 the auto set targets will be in the left and right down in the middle of the booth. The Prototype model shown below in figure 27 is the initial Prototype design of the proposed system.



Figure 24: Prototype Design

### 6.1 Resources

For this system, the project resources that will be needed are shown in the following table.

Table 1.6: Resources

Resources	Material
Slingshot Rubber	Rubber
Slingshot Frame	Steel
Slingshot Prong	Steel
Slingshot clips	Steel
Slingshot base	Steel
SPI Sponge Ball	Plastic
Hook	Plastic
Pouch	Leather
Fence	Plastic
Boxing Balls	Rubber
Pole	Wood
Color	Powder

Room walls	Wood
------------	------

We will be using all the materials that provided to us to create our project. We will using a lest of equipment listed in the down table:

Table 1.6: Resources

Equipment	Uses
Circular saw	Cutting the wood and the steel
Tap Metal	Creates screw thread
Hammer	Hitting the nails
Welding machine	Weld the metal
Screwdriver	Install the screws
Brush	Paint the walls
Drill	Makes holes into a wall

## 6.2 BOM

A bill of materials states all the parts, which will used to build the project and the material of each item that will be used. The bill of materials is important for any project and it has helped us because we now have a list for the items that will have to be bought for building the project. Now, we know that the structure of our product will consist of plastic and the slingshot will consist of the iron rod and rubber band. In this way the BOM made it easy to implement the project. The bill of materials is shown in appendix A.

## 6.3 Cost and Budget

The budget to implement this project is shown in the following table for each item.



Table 1.7: Cost

<b>Item</b>	<b>Cost</b>
Slingshot Rubber	\$7.59
Slingshot Frame	\$8.45
Slingshot Prong	\$8.45
Slingshot clips	\$7.29
Slingshot base	\$21.98
SPI Sponge Ball	\$10.98
Hook	\$8.55
Pouch	\$35
Fence	\$30
Boxing Balls	\$30
Pole	\$3.98
Paint color	\$28.98
Room walls	\$200-\$300
<b>Total</b>	<b>\$401.25-\$501.25</b>

## 6.4 Schedule

The schedule for presentations next semester is in the Gantt chart in Appendix B. A Gantt chart is a useful way to describe the schedule because it mentions the deadlines in a visual form. And with the help of this chart, the project can be completed on time because we will track the work and see if we are behind schedule or ahead.

## References

- [1] L. Chakrabarti, “Drm, a design research methodology”. 2014, Heidelberg: Springer.
- [2] W. Bechtel, C. Richardson, “Discovering complexity: Decomposition and localization as strategies in scientific research” 2014
- [3] N. Wales, “Design research. Paddington, N.S.W” 2010 School of Design Studies, University of New South Wales.
- [4] A. Smailagic, “System level design” 2011, New York, NY.
- [5] Amazon, “Trumark Slingshot”, available [online]. <https://www.amazon.ca/Trumark-Slingshots-Normal-Pull-Slingshot/dp/B000PI18TY>
- [6] H. List, “Top rated Slingshot”, available [online], <https://huntingslingshots.net/>
- [7] B. Bernhard, “Slingshot”, available [online], <http://www.offthegridnews.com/extreme-survival/slingshots-the-low-cost-easy-to-use-compact-hunting-tool-that-can-fit-anywhere/>
- [8] T. Shot, “Slingshot Shooting”, available [online], <http://slingshot-shooting.de/photos/torsten/torsten.html>
- [9] C. Bunny, “Custom Slingshot”, available [online], <http://www.bunnybuster.com/hammermilhunter.htm>
- [10] C. Bucker, “How to Slingshot Hunt and Prepare”, available [online], <http://www.wideopenspaces.com/slingshot-hunt-prepare-chipmunks-squirrels/>
- [11] Commerce, G. (2017). The Wonder Factory - Greater Flagstaff Chamber of Commerce. [online] Greater Flagstaff Chamber of Commerce. Available at: <https://www.flagstaffchamber.com/wonder-factory-3/>

## APPENDIX A: Bill of Materials

Table A1: Bill of Materials

Bill of Materials						
Item #	Part Name	Quantity	Description	Source	Dimension	Price
1.1	Slingshot Rubber	1	Rubber for stretching	<a href="https://www.amazon.com/Yosoo-Natural-Slingshot-Catapult-Surgical/dp/B0151WK14O/ref=sr_1_2?s=sporting-goods&amp;ie=UTF8&amp;qid=1510107611&amp;sr=1-2&amp;keywords=slingshot+rubber">https://www.amazon.com/Yosoo-Natural-Slingshot-Catapult-Surgical/dp/B0151WK14O/ref=sr_1_2?s=sporting-goods&amp;ie=UTF8&amp;qid=1510107611&amp;sr=1-2&amp;keywords=slingshot+rubber</a>	6x9mm	\$7.59
1.2	Steel Tubing [Slingshot Frame]	1	Base to stand up and rubber band will attach to it	<a href="https://www.onlinemetals.com/merchant.cfm?pid=7791&amp;step=4&amp;showunits=inches&amp;id=283&amp;top_cat=0">https://www.onlinemetals.com/merchant.cfm?pid=7791&amp;step=4&amp;showunits=inches&amp;id=283&amp;top_cat=0</a>	12 ft.	\$8.45
1.3	Steel Tubing [Slingshot Prong]	1	A Y shaped element to tie the rubber band	<a href="https://www.onlinemetals.com/merchant.cfm?pid=7791&amp;step=4&amp;showunits=inches&amp;id=283&amp;top_cat=0">https://www.onlinemetals.com/merchant.cfm?pid=7791&amp;step=4&amp;showunits=inches&amp;id=283&amp;top_cat=0</a>	12 ft.	\$8.45

1.4	Slingshot clips	6	To hold slingshot rubber band	<a href="https://www.e-rigging.com/seven-sixteenths-inch-stainless-snap-link?gclid=EAlaIQobChMI1biH9_et1wIVSLnACh1RGQgDEAQYAyABEgLL3PD_BwE">https://www.e-rigging.com/seven-sixteenths-inch-stainless-snap-link?gclid=EAlaIQobChMI1biH9_et1wIVSLnACh1RGQgDEAQYAyABEgLL3PD_BwE</a>	7/16 in	\$7.29
1.5	Slingshot base	1	Hold the slingshot frame	<a href="https://www.homedepot.com/p/M-D-Building-Products-36-in-x-36-in-Plain-Aluminum-Sheet-in-Silver-57000/100351161">https://www.homedepot.com/p/M-D-Building-Products-36-in-x-36-in-Plain-Aluminum-Sheet-in-Silver-57000/100351161</a>	36 in. x 36 in	\$21.98
1.6	SPI Sponge Ball	1	Ball to throw	<a href="https://www.spri.com/products/sponge-ball?variant=33857849360&amp;gclid=EAlaIQobChMIioy5wtyD2AIVSEsNCh34-gyfEAQYASABEGJVs_D_BwE">https://www.spri.com/products/sponge-ball?variant=33857849360&amp;gclid=EAlaIQobChMIioy5wtyD2AIVSEsNCh34-gyfEAQYASABEGJVs_D_BwE</a>	9-inch	\$10.98

1.7	Hook	3	Hook to hold items	<a href="https://www.aliexpress.com/store/product/50pcs-Garden-Supplies-Greenhouse-Accessories-Black-Shade-Net-Clips-Holder-Fasten-Shading-System-Hook/1296231_32701104408.html">https://www.aliexpress.com/store/product/50pcs-Garden-Supplies-Greenhouse-Accessories-Black-Shade-Net-Clips-Holder-Fasten-Shading-System-Hook/1296231_32701104408.html</a>	3 x 3 in	\$8.55
1.8	Boxing Balls	1	Target	<a href="https://www.aliexpress.com/item/Muay-Thai-boxer-target-Boxing-sport-of-MMA-ball-speed-ball-standing-boxing-bag-mma-punch/32437018234.html">https://www.aliexpress.com/item/Muay-Thai-boxer-target-Boxing-sport-of-MMA-ball-speed-ball-standing-boxing-bag-mma-punch/32437018234.html</a>	5 x 3 in	\$30
1.9	Fence	3	Boundary walls	<a href="https://www.alibaba.com/product-detail/Hot-Dipped-Galvanized-Temporary-Construction-Fence_848542709.html?spm=a2700.7724838.2017115.">https://www.alibaba.com/product-detail/Hot-Dipped-Galvanized-Temporary-Construction-Fence_848542709.html?spm=a2700.7724838.2017115.</a>	2100mm H x 2400mm L	\$30

				297.3bf82f3bUUr Zec		
<b>2.0</b>	Sand bags	3	Hold the base and fence from moving	<a href="https://www.homedepot.com/p/14-in-x-26-in-White-Polypropylene-Sandbag-100-Pack-14981-10-14/204277293">https://www.homedepot.com/p/14-in-x-26-in-White-Polypropylene-Sandbag-100-Pack-14981-10-14/204277293</a>	14 in. x 26 in	\$35
<b>2.1</b>	Pole	3	Standing Up	<a href="https://www.homedepot.com/p/1-in-x-48-in-Wood-Round-Dowel-HDDH148/203360196">https://www.homedepot.com/p/1-in-x-48-in-Wood-Round-Dowel-HDDH148/203360196</a>	1 in. x 48 in	\$3.98
<b>2.2</b>	Paint color	3	To dye items	<a href="https://www.homedepot.com/p/BEHR-Premium-Plus-1-gal-Ultra-Pure-White-Semi-Gloss-Enamel-Zero-VOC-Interior-Paint-and-Primer-in-One-305001/202761530">https://www.homedepot.com/p/BEHR-Premium-Plus-1-gal-Ultra-Pure-White-Semi-Gloss-Enamel-Zero-VOC-Interior-Paint-and-Primer-in-One-305001/202761530</a>	1 gal	\$28.98
<b>2.3</b>	Room walls	4	Wood walls	Not specified yet	3m x 3 m	\$200-\$300

## APPENDIX B: Gantt Chart

Table B1: Gantt chart

